

# SERVICE CARTS - SCS2-2236

APPROX WEIGHT: 84.41 lbs.  
 DOES NOT INCLUDE WEIGHT OF POWER OR PACKAGING!!!

\*\*\* ANY ADDITIONS, DELETIONS, OR OMISSIONS MUST BE CORRECTED ON THIS DRAWING AS THIS DRAWING WILL BE CONSIDERED ALL INCLUSIVE \*\*\*

ALL GRAPHICS PROVIDED ARE FOR REFERENCE ONLY. IF CERTAIN DIMENSIONS ARE CRITICAL PLEASE VERIFY THOSE DIMENSIONS WITH YOUR SALESPERSON

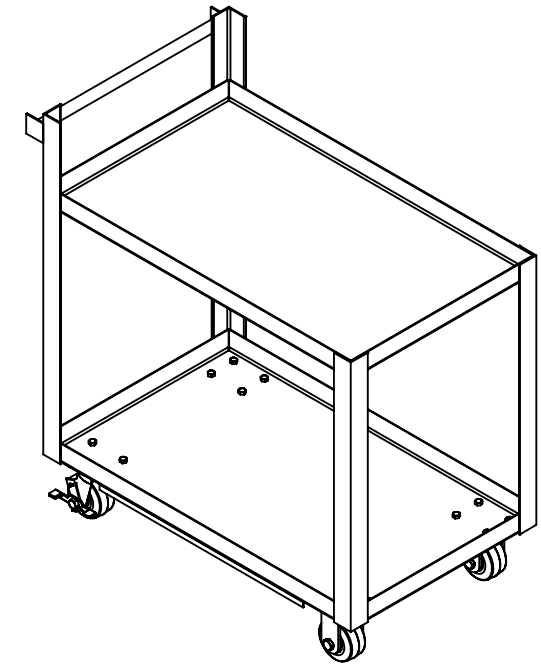
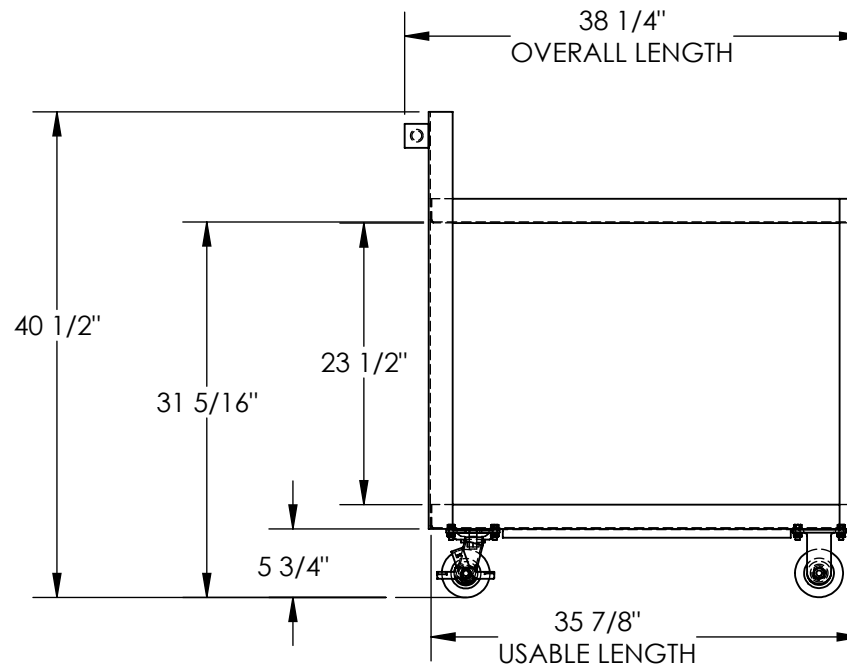
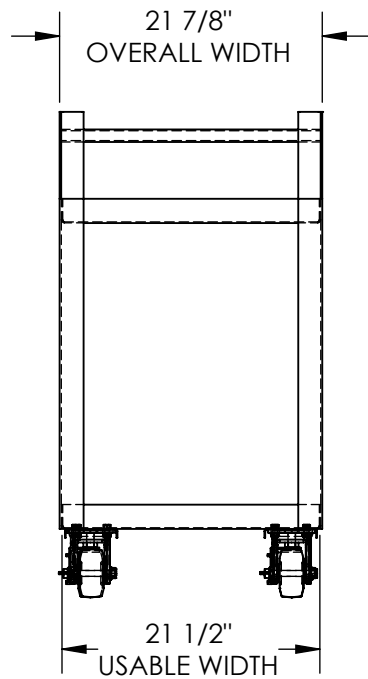

DIMENSION TOLERANCE ± 1/4"

## STANDARD FEATURES

- MODEL NUMBER IS SCS2-2236
- OVERALL WIDTH IS 21 7/8"
- USABLE WIDTH IS 21 1/2"
- OVERALL LENGTH IS 38 1/4"
- USABLE LENGTH IS 35 7/8"
- OVERALL HEIGHT IS 40 1/2"
- MAX CAPACITY IS 1,000 lbs. (550 LBS. PER SHELF)
- STEEL FRAME CONSTRUCTION
- SHELF CLEARANCE 23 1/2"
- USABLE TOP SHELF HEIGHT IS 31 5/16"
- TOUGH BAKED IN POWDER COATED BLUE FINISH
- Ø4" X 2" MOLD ON RUBBER
- 2 - SWIVEL CASTERS WITH BRAKE
- 2 - RIGID CASTERS

## SPECIAL FEATURES

NONE

<b>APPROVAL</b>	I, THE UNDERSIGNED, AGREE THAT THE PRODUCT AS REPRESENTED SATISFIES DESIGN AND DIMENSION REQUIREMENTS. I ALSO ACKNOWLEDGE MY DUTY TO CONFIRM PRODUCT AND INSTALLATION COMPLIANCE WITH ALL APPLICABLE FEDERAL, STATE AND LOCAL REGULATIONS AND STANDARDS.	
	<b>UNITS REQUIRING APPROVAL DRAWINGS OR MODIFIED ARE NON-RETURNABLE</b>	
	[ ] As drawn      [ ] As marked	
	Signed: _____ Date: _____	
	Printed Name: _____	
	<b>LEAD TIME WILL START UPON RECEIPT OF SIGNED APPROVAL DRAWING</b>	

DISTRIBUTOR'S NAME:		P.O.#
VESTIL MANUFACTURING		X
DRAWN BY: B.HORN		DATE: 07/16/2014
REFERENCE: X		SCALE: 1:16
QUOTED LEAD TIME: X		QUOTE # X
		SALES: X
		FILE NAME: 16-007-106